

ALUMINIUM REFINING SYSTEM

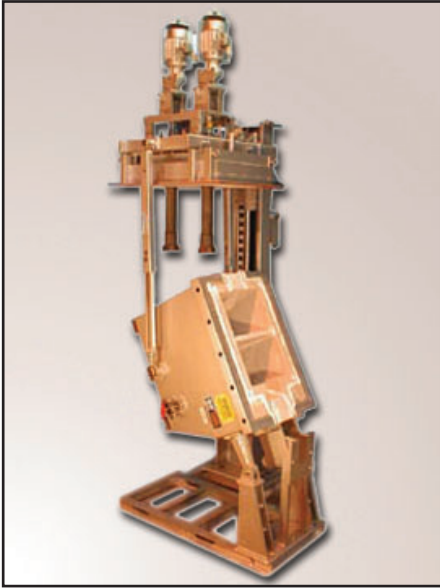

SNIF TD-1500 in fully tilted position.

The SNIF™ TD-1500 Double Nozzle Refining System is a low cost, unheated, small footprint unit that provides nominal continuous refining rate up to 60,000 lb (27,000 kg) per hour. The system consists of an unheated refining furnace with integrated hydraulic cover lift / vessel tilt apparatus, and process control station.

For optimum efficiency the TD-1500 is divided into two separate and distinct refining chambers, each equipped with a SNIF SHEER spinning nozzle mounted to the furnace cover. Each chamber is designed to optimize process gas bubble saturation throughout the melt and to maximize spinning

nozzle refining efficiency. The inlet and outlet connections are located on opposite ends of the vessel for an in-line metal flow configuration. Patented trough airlocks installed in the inlet and outlet ports allow metal to flow freely through the vessel, at the same time preventing air infiltration, a cause of excessive dross formation.

The refining furnace is lined with easily replaceable refractories designed to minimize heat loss. Molten aluminium can be maintained in the vessel without the use of a heating system if the time between casts is short.

One of the system's unique features is a single integrated mechanism that raises the cover and tilts the vessel for emptying the metal into the outlet launder at the end of the cast. When the cover is raised the entire surface of the bath is exposed to facilitate dross removal and cleaning. In the closed position the cover provides an excellent perimeter seal that prevents air infiltration.

OPTIONS

The TD-1500 can be ordered with the following options:

- An alternate tilting configuration to allow the molten aluminium to be emptied at the end of a cast, perpendicular to the casting line into a sow.
- A gas heater for preheating the furnace.

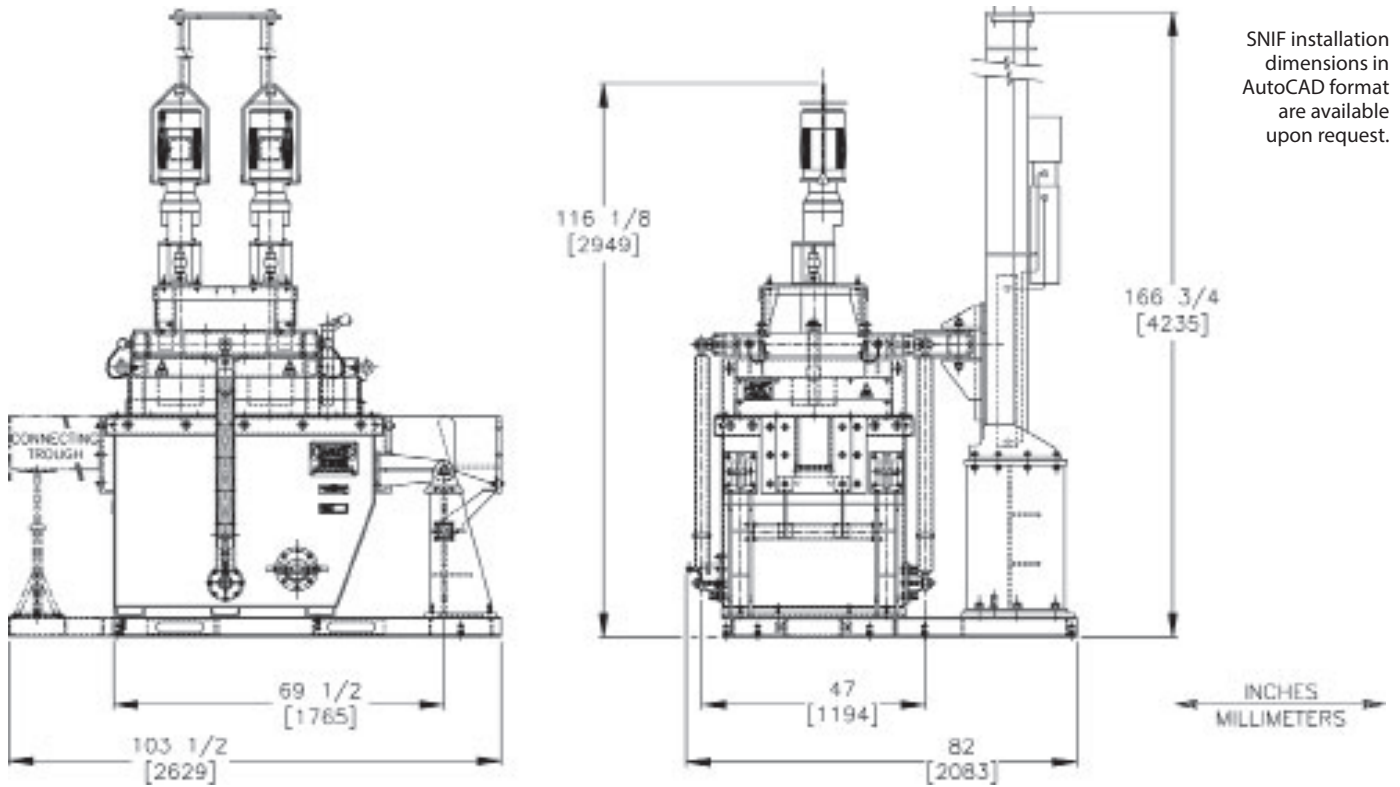

SNIF installation dimensions in AutoCAD format are available upon request.

TOTAL ELECTRICAL LOAD (MAXIMUM)*

TD-1500	15 Kw – 3 Phase
Cover Lifter	2 Kw – 3 Phase
*Primary voltage per customer requirements. Refer to installation drawings for electrical interconnection specifications for the equipment provided.	

GAS SUPPLY REQUIREMENTS

	ENGLISH	METRIC
Process Gas (Argon recommended)	600 scfh at 70–90 psig (max.)	15.8 Nm ³ /hr at 4.9–6.3 kg/cm ² (max.)
Cover Lift Mast (Plant Air)	60 to 90 psig	4.2 to 6.3 kg/cm ²
Chlorine, if required	21 scfh at 30 psig (max.)	0.6 Nm ³ /hr at 2.1 kg/cm ² (max.)
scfh=standard cubic feet/hour (70°F, 14.696 psia) Nm ³ /hr =normal cubic meter/hour (0°C, 1.01325 bar, abs.)		1 Nm ³ /hr = 38.0 SCFH 1 kg/cm ² =14.2 psi

GENERAL SPECIFICATIONS

	ENGLISH	METRIC
Refining furnace capability, nominal	60,000 lb/hr	27,000 kg/hr
Furnace static capacity	1,600 lb	710 kg
Estimated furnace assembly weight including cover, static metal capacity, cover lift assembly, and spinning nozzles	11,200 lb	5,080 kg

Note: The physical and chemical properties listed represent typical, average values obtained in accordance with accepted test methods and are subject to normal manufacturing variations. They are supplied as a technical service and are subject to change without notice.

Product Type: 118
Commodity Code: 16004