

## CERAMIC SHROUD USED TO BLOCK AIR

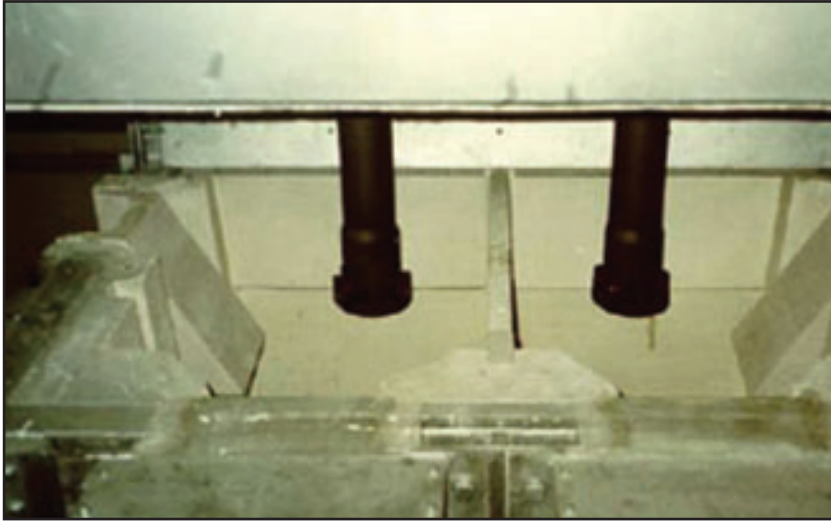

Trough airlocks installed in SNIF furnace ports.

The trough airlock is a ceramic shroud that fits snugly in the inlet and outlet trough ports of your SNIF refining furnace.

The trough airlocks block air from entering the furnace. By blocking out air, inerting of the refining chambers will be improved. This will increase nozzle life and reduce dross formation. The airlock also acts as a skimmer of metal entering and exiting the furnace. The benefits can be realized within a few days of operation. Although access to the chamber through the inlet/outlet ports is restricted when airlocks are in place, the need for frequent furnace cleaning is also reduced because less dross and roof build-up forms.

No longer will an operator have to make conscious efforts to seal the hot trough openings between casting runs. We recommend placing a trough air seal pad over the opening to retain heat. Because the airlock does not decrease chamber volume, degassing efficiency will remain unchanged.

Trough airlocks are available for all SNIF R and P systems, except the R10 and P30. Please contact us for the correct trough airlock part number and pricing for your SNIF System.

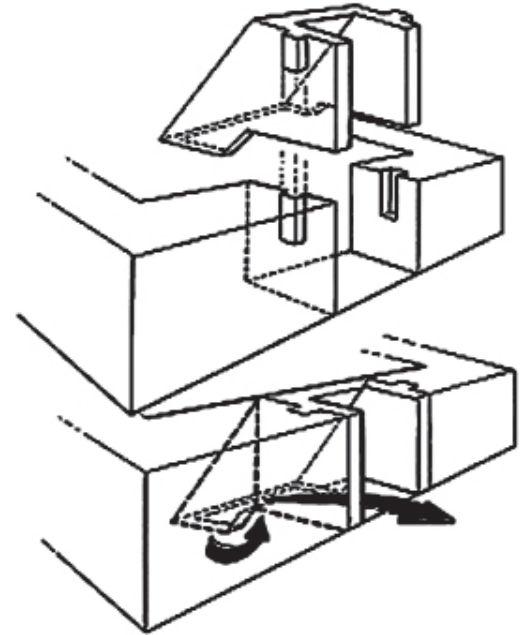

SNIF trough airlock before and after installation

Note: The physical and chemical properties listed represent typical, average values obtained in accordance with accepted test methods and are subject to normal manufacturing variations. They are supplied as a technical service and are subject to change without notice.

Product Type: 171

Commodity Code: 16022